



City of Port Lincoln

Template No 16-71-T3

Address: Level One, Civic Centre, 60 Tasman Terrace, Port Lincoln SA 5606
Postal Address: PO Box 1787, Port Lincoln SA 5606
Email: plcc@plcc.sa.gov.au **Web:** www.portlincoln.sa.gov.au
Telephone: (08) 8621 2300 **Fax:** (08) 8621 2399

NORTH SHIELDS GARDEN CEMETERY

APPLICATION FOR PERMIT TO ERECT A HEADSTONE OR ADDITIONAL INSCRIPTION

Name of Monumental Mason and/or Applicant:	
Postal Address:	
Phone:	Email:

Hereby make application for permission to undertake the following in the North Shields Garden Cemetery:

- erect a headstone
- add additional inscription on an existing headstone

Full name of Deceased:		
Allotment:	Section:	Row:
Date of Erection (Approximate):	Date of Additional Inscription (Approx):	<input type="checkbox"/> Permit fee enclosed (GST exempt) Please refer to Council's current fees and charges schedule, available at www.portlincoln.sa.gov.au → Documents → Fees and Charges or the Council Office

Note: Headstones must not exceed the following dimensions, sizes in millimetres:

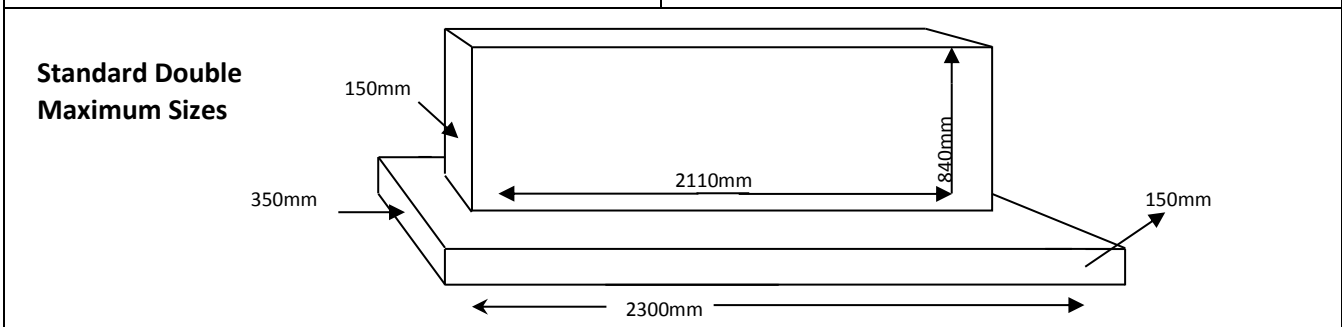

Instructions to Monumental Masons regarding use of standard application for Memorial

- | | |
|---|---|
| <ul style="list-style-type: none"> • Applications not accepted unless signed by grant holder or authorised representative • Sketch of monument to show full measurements and dimensions on back of form or attached • Application to be forwarded with correct fees or by credit arrangement • Minimum time to process permits 48 hours • All applications subject to regulation of cemetery authority | <ul style="list-style-type: none"> • Applications only accepted on prescribed form - not those of Monumental masons • Full detail of proposed inscription (new or additional) and accurate translations of inscriptions if not in English on back of form or attached • Variations to the headstone dimensions may be approved provided the base dimensions and an overall height (inclusive of base) of 1m are not exceeded |
|---|---|

NOTE:

- NO inscription or markings will be allowed on the back of monuments
- Masons/Applicant to present a copy of approved permit to authorised cemetery staff before memorial is installed, or before any additional inscription is added

Signature: _____

Date: _____

DETAILS OF HEADSTONE DESIGN (HEIGHT, WIDTH & DEPTH IN MM) & TYPE OF STONE:

WORDING OF THE INSCRIPTION TO BE INSCRIBED ON THE MONUMENT (NEW OR ADDITIONAL):

EXAMPLE DRAWING OF HEADSTONE DESIGN WITH MEASUREMENTS:

PLEASE ATTACH PHOTO OF STONE FOR PRIVATE WORKS

OFFICE USE ONLY:

Interment Right No:		Burial Reg. No.	Section:	Row:	Allotment:
Amount Owing		Cashier Receipt Number:	Date:		
Approved: <input type="checkbox"/> Yes <input type="checkbox"/> No	Applicant notified: <input type="checkbox"/> Yes <input type="checkbox"/> No	Manager Infrastructure signature:	Community	Cemetery Curator confirmation that works have been undertaken as per application:	